

INSTRUCTION GUIDE: BST-R SERIES WHEELS

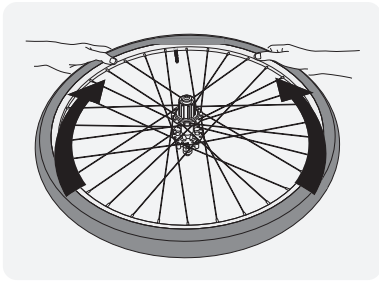

1



Mount tire: Making sure to position the tire bead in the center channel of the rim, mount one tire bead beginning opposite the valve and finishing at the valve. Once the first bead is mounted begin mounting the second bead opposite the valve and finish at the valve.

NEEDED:

Stan's NoTubes ZTR wheel set, 2 tires, Stan's NoTubes Tire Sealant, core remover tool, injector or 2 oz. bottle, floor pump or compressor, soapy water, safety goggles.

WARNING:

Always wear safety goggles, Sealant can stain clothes or furniture.

IMPORTANT NOTE:

Never inflate any tire without a tube above 40psi unless it is specifically labeled for tubeless use. Maximum pressure listed on your rims may differ from maximum pressure listed on your tires. Do not inflate above the lower of the two numbers.

2

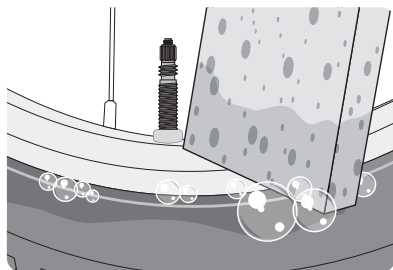

With a brush or sponge apply a generous amount of soapy water to both beads of the tire to help it slip onto the bead of the rim when inflating.

3

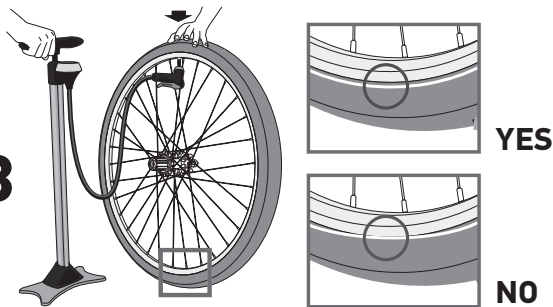

Rotate the valve to 12 o'clock and install a pump. Determine the type of tire being installed. Tires originally intended for use with tubes, including cyclocross tires and most tires wider than 35mm, should be inflated to 35psi to seat onto the rim and should never be inflated above 40psi. Tires specifically designated as "Tubeless" may be inflated to the maximum pressure listed on the sidewall of the tire or the maximum pressure listed on the rim label (whichever is lower).

4

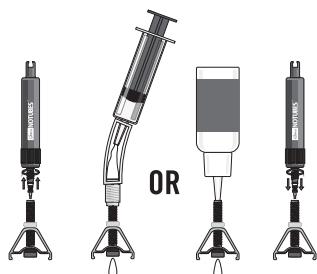

Add sealant: Once successful with inflation remove the valve core to add Stan's sealant. Add 2-3 oz. of sealant.

RECOMMENDED ROAD TIRE PRESSURE

5

Inflate to riding pressure. Always review the maximum pressure information listed on both the rim and the tire and consider the lower of the two numbers as your maximum allowable pressure. Do not inflate above the lower of the two numbers.

6

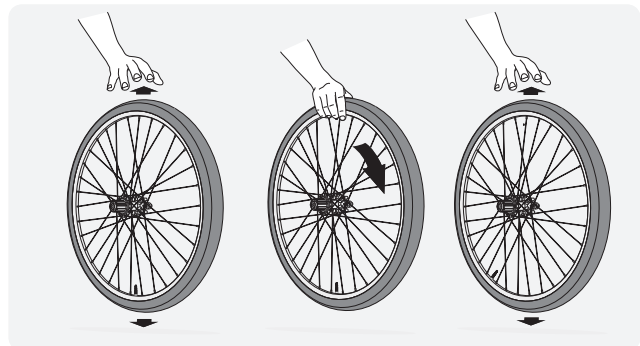

Bounce: hold the wheel vertically and gently bounce or "dribble" it to disperse the sealant throughout the inside of the tire. Let it drop from an inch or two, then rotate a few degrees and repeat. Do this for several revolutions of the wheel.

7

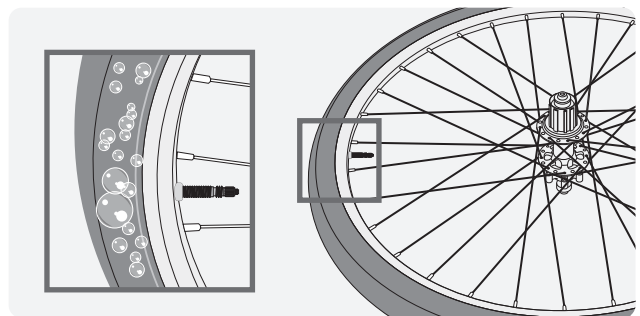

Lay tire on side and apply a thin sheen of soapy water around the sidewall and the bead area. Look for suds occurring anywhere on the tire or bead area. Suds bubbling out from the tire indicate porous areas. Shake the sealant to those areas to seal them and apply soap and water again. Check for suds forming on both sides of the tire. Repeat until no suds remain. Install the cassette and rotors according to the component manufacturer's recommendations.

STAN'S NOTUBES ZTR RIM SETUP GUIDE: BST-R SERIES WHEELS



RIMS	WEIGHT	BRAKES	ERD	SPOKE TENSIONS (KGF)	Yellow Tape and Valve Compatibility			PV			
					21mm	25mm	27mm	35mm	44mm	55mm	
Avion Disc	415g	Disc	559	105		2X					X
Grail	460g	Disc	590	125	2X	2X				X	
Alpha 340	385g	Rim	592	125	2X					X	
Alpha 400	425g	Rim	592	125	2X					X	

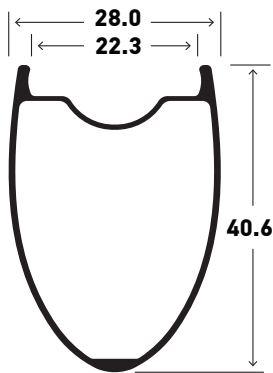

AVION

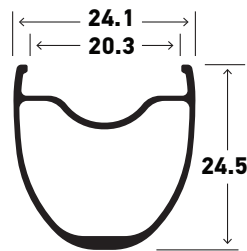

GRAIL

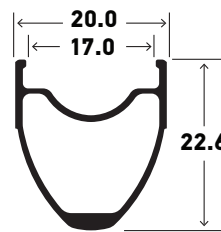

ALPHA 340

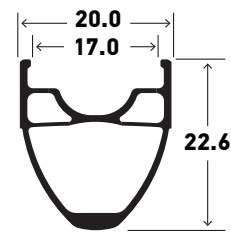

ALPHA 400

RIMS:

Avion

Grail

Alpha 340

Alpha 400

ZTR Rims are optimized for tubeless use and are designed to set up tubeless with Stan's Yellow Tape, Universal Tubeless Valves, and Tire Sealant. Tubes may be used on all ZTR rims, though, as with all tube installations, extra care should be taken when mounting the tire, as improperly installed tubes can get caught underneath the bead of the tire and cause the tire to dismount when inflated.

Spokes and Spoke Nipples:

The rim does not use eyelets and therefore spoke nipples must be lubricated to aid in the wheelbuilding/truing process. NoTubes recommends synthetic 0 weight oil but any light oil will work.

Rim Tape:

Stan's NoTubes Yellow Rim Tape is designed for use with ZTR rims, and the use of other tapes is not recommended. BST-R rims require two layers of Yellow tape (see above chart for width).

Tubeless Setup:

Important: Never inflate any tire without a tube above 40psi unless it is specifically labeled for tubeless use. Maximum pressure listed on your rims may differ from maximum pressure listed on your tires. Do not inflate above the lower of the two numbers.

Spoke Tension:

Check the chart above for correct tensions. Do not over tension the spokes. If spokes are over-tensioned damage to the wheel may occur.

Watch our how-to video at: <http://www.notubes.com/help/>

NOTUBES.COM • 202 Daniel Zenker Dr., Big Flats, NY14814 • (607) 562-2877 • sales@notubes.com

EIS-012 R1 ZTR Rim and Wheelset Instructions: BST-R Series